

H-132-OSA

3 1/4" X 1 5/8"
12 Gauge Back-to-Back
wt./100 ft. - 378#

Stocked in pre-galvanized, plain, powder coated Supr-Green, zinc trivalent, PVC coated & aluminum, in 10 & 20 ft. lengths.
 Note: Also available in Stainless Steel 304 & 316 Alloys. Other materials, finishes, lengths and configurations are available upon request.

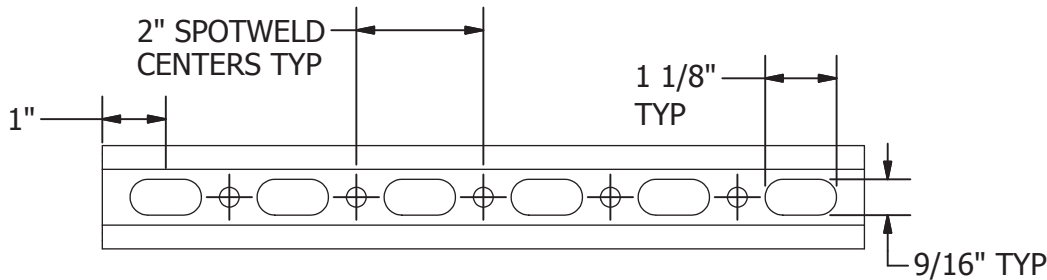
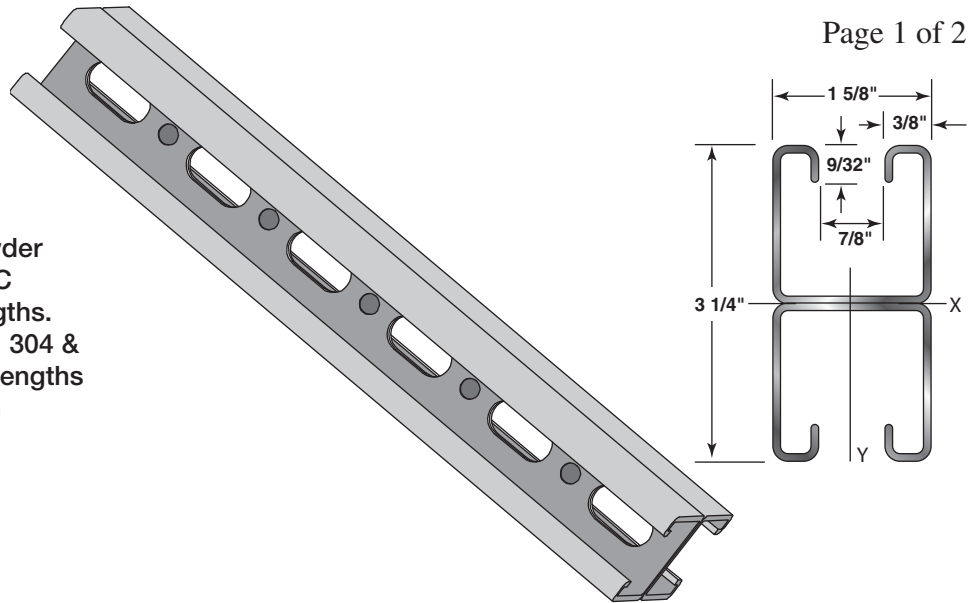

Specifications

GENERAL

H-STRUT channels are manufactured by a series of forming dies, or rolls, which progressively cold work the strip steel into the desired channel configuration. This method produces a cross section of uniform dimensions within a tolerance of plus or minus 0.015", on outside dimensions.

WELDING

Channel combinations of two or more elements are spot welded together to form various multiple combinations. The spot welds are spaced two inches on centers throughout the length of the multiple channel sections.

LENGTH INFORMATION

H-STRUT Channels are produced and stocked in 10' and 20' lengths with a tolerance of $\pm 1/8"$. Other lengths are available upon request.

LOADING DATA

1. When calculating load at center of span, multiply load from table by 0.5 and deflection by 0.8.
2. When calculating beam and column loads for aluminum, multiply by 33%.

MATERIAL

H-STRUT channels are produced from prime structural steel covered by the following specifications. (See technical section for additional information)

- Pre-Galvanized SteelASTM A-653
- Plain SteelASTM A-1011-04-SS
- Aluminum (Type 6063T6)ASTM B-221
- Stainless Steel (Type 304 & 316)ASTM A-240

Other materials and specifications available on request.

FINISHES

All H-STRUT channels are stocked in pre-galvanized and powder coated Supr-Green. Some sizes are stocked in zinc trivalent chromium, PVC or hot dipped galvanized.

- Hot Dipped Galvanized.ASTM A-123
- Zinc Trivalent Chromium.ASTM B-633-85
- Powder Coated Supr-Green.ASTM B-117
- PVC Coating 40 ML Thickness - Available Upon Request

H-132-OSA

3 1/4" X 1 5/8"
 12 Gauge Back-to-Back
 wt./100 ft. - 378# (Cont.)

SECTION PROPERTIES

Catalog No.	Wt./Ft. Lbs.	Area of Section Sq. In.	X-X Axis			Y-Y Axis		
			I in ⁴	S in ³	r in.	I in ⁴	S in ³	r in.
H-132-OSA	3.78	1.104	0.947	0.583	0.926	0.473	0.582	0.655

I = Moment of Inertia S = Section Modulus r = Radius of Gyration

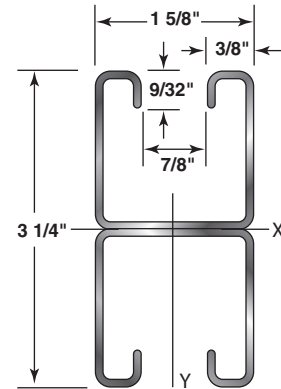

Span or Unbraced Height (In)	Static Beam Load (X-X Axis)							Column Loading Data			
	Max Allowable Uniform Load (Lbs)	Deflection at Uniform Load (In)	Uniform Load at Deflection				Max. Allowable Load at Slot Face (Lbs)	Max. Column Load Applied at C.G.			
			Span/180 Deflection (Lbs)	Span/240 Deflection (Lbs)	Span/360 Deflection (Lbs)	Weight of Channel (Lbs)		k=.65 (Lbs)	k=.80 (Lbs)	k=1.0 (Lbs)	k=1.2 (Lbs)
12	3,500 *	0.01	3,500 *	3,500 *	3,500 *	3.9	6,640	25,540	25,430	25,240	25,020
18	3,500 *	0.02	3,500 *	3,500 *	3,500 *	5.8	6,580	25,270	25,020	24,610	24,120
24	3,500 *	0.03	3,500 *	3,500 *	3,500 *	7.8	6,510	24,890	24,460	23,750	22,920
30	3,500 *	0.05	3,500 *	3,500 *	3,500 *	9.7	6,410	24,420	23,750	22,690	21,460
36	3,260	0.07	3,260	3,260	3,260	11.6	6,300	23,850	22,920	21,460	19,800
42	2,790	0.10	2,790	2,790	2,790	13.6	6,170	23,190	21,970	20,090	18,010
48	2,440	0.13	2,440	2,440	2,440	15.5	6,030	22,460	20,930	18,620	16,140
60	1,950	0.20	1,950	1,950	1,660	19.4	5,690	20,790	18,620	15,510	12,410
72	1,630	0.28	1,630	1,630	1,150	23.3	5,310	18,920	16,140	12,410	8,990
84	1,400	0.39	1,400	1,270	840	27.2	4,890	16,920	13,630	9,510	6,600
96	1,220	0.50	1,220	970	650	31.0	4,450	14,880	11,220	7,280	5,060
108	1,090	0.64	1,020	770	510	34.9	3,980	12,860	8,990	5,750	3,990
120	980	0.79	830	620	410	38.8	3,560	10,930	7,280	4,660	**
144	810	1.13	570	430	290	46.6	2,870	7,660	5,060	**	**
168	700	1.54	420	320	210	54.3	**	5,630	**	**	**
180	650	1.77	370	280	180	58.2	**	4,900	**	**	**
192	610	2.01	320	240	160	62.1	**	4,310	**	**	**
216	540	2.55	260	190	130	69.8	**	**	**	**	**
240	490	3.15	210	160	100	77.6	**	**	**	**	**

Bearing Load may limit load

* Load limited by spot weld shear

** Not recommended - KL/r exceeds 200

Notes

- The beam capacities shown above include the weight of the strut beam. The beam weight must be subtracted from these capacities to arrive at the net beam capacity.
- Refer to the latest Haydon Engineering Catalog in our Literature Section for reduction factors for unbraced lengths or call us 1-800-2-HAYDON.

3. Allowable beam loads are based on a uniformly loaded, simply supported beam. For capacities of a beam loaded at midspan at a single point, multiply the beam capacity by 50% and deflection by 80%.

4. The above chart shows beam capacities for strut without holes. For strut with holes, multiply by the following:
 OS by 88%.

Project Information			
Project:		Notes:	
Address:			
Contractor:			
Engineer:	Date:		
Approval			
<input type="checkbox"/> Approved <input type="checkbox"/> Approved as Noted <input type="checkbox"/> Not Approved		Signature:	
		Remarks:	