

H-112-OSA

6 1/2" X 1 5/8"

12 Gauge Back-to-Back
wt./100 ft. - 616#

Stocked in pre-galvanized, plain & powder coated Supr-Green, in both 10 & 20 ft. lengths. Note: Also available in Stainless Steel 304 & 316L Alloys. Other materials, finishes, lengths and configurations are available upon request.

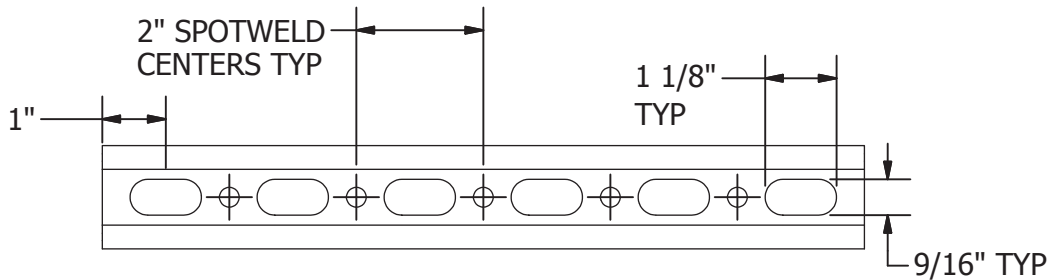
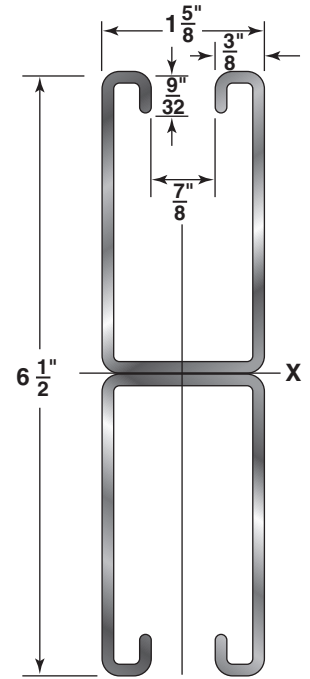
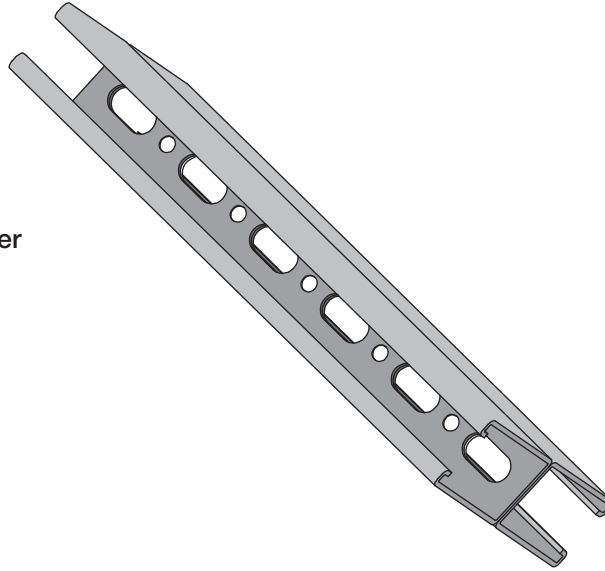

and 20' lengths with a tolerance of $\pm 1/8"$.
Other lengths are available upon request.

LOADING DATA

1. When calculating load at center of span, multiply load from table by 0.5 and deflection by 0.8.
2. When calculating beam and column loads for aluminum, multiply by 33%.

MATERIAL

H-STRUT channels are produced from prime structural steel covered by the following specifications.
(See technical section for additional information)

- Pre-Galvanized SteelASTM A-653
- Plain SteelASTM A-1011-04-SS
- Aluminum (Type 6063T6)ASTM B-221
- Stainless Steel (Type 304 & 316L)ASTM A-240

Other materials and specifications available on request.

FINISHES

All H-STRUT channels are stocked in pre-galvanized and powder coated Supr-Green. Some sizes are stocked in zinc trivalent chromium, PVC or hot dipped galvanized.

- Hot Dipped Galvanized.ASTM A-123
- Zinc Trivalent Chromium.ASTM B-633-85
- Powder Coated Supr-Green.ASTM B-117
- PVC Coating 40 ML Thickness - Available Upon Request

H-112-OSA

6 1/2" X 1 5/8"
 12 Gauge Back-to-Back
 wt./100 ft. - 616# (Cont.)

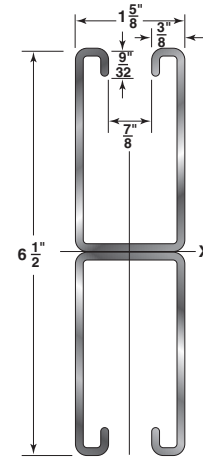

SECTION PROPERTIES

Catalog No.	Wt./Ft. Lbs.	Area of Section Sq. In.	X-X Axis			Y-Y Axis		
			I in ⁴	S in ³	r in.	I in ⁴	S in ³	r in.
H-112-OSA	6.16	1.775	6.251	1.923	1.877	0.862	1.060	0.697

I = Moment of Inertia S = Section Modulus r = Radius of Gyration

Span or Unbraced Height (In)	Static Beam Load (X-X Axis)						Max. Allowable Load at Slot Face (Lbs)	Column Loading Data			
	Max Allowable Uniform Load (Lbs)	Deflection at Uniform Load (In)	Uniform Load at Deflection					Max. Column Load Applied at C.G.			
			Span/180 Deflection (Lbs)	Span/240 Deflection (Lbs)	Span/360 Deflection (Lbs)	Weight of Channel (Lbs)		k=.65 (Lbs)	k=.80 (Lbs)	k=1.0 (Lbs)	k=1.2 (Lbs)
12	6,890 *	0.00	6,890 *	6,890 *	6,890 *	6.3	10,910	41,100	40,940	40,680	40,360
18	6,890 *	0.01	6,890 *	6,890 *	6,890 *	9.4	10,860	40,720	40,360	39,780	39,080
24	6,890 *	0.02	6,890 *	6,890 *	6,890 *	12.5	10,780	40,180	39,560	38,550	37,360
30	6,890 *	0.02	6,890 *	6,890 *	6,890 *	15.7	10,690	39,500	38,550	37,030	35,250
36	6,890 *	0.04	6,890 *	6,890 *	6,890 *	18.8	10,570	38,690	37,360	35,250	32,840
42	6,890 *	0.05	6,890 *	6,890 *	6,890 *	21.9	10,440	37,750	35,990	33,260	30,200
48	6,890 *	0.06	6,890 *	6,890 *	6,890 *	25.0	10,280	36,700	34,480	31,100	27,420
60	6,450	0.10	6,450	6,450	6,450	31.3	9,900	34,280	31,100	26,470	21,740
72	5,370	0.14	5,370	5,370	5,370	37.6	9,440	31,540	27,420	21,740	16,370
84	4,610	0.19	4,610	4,610	4,610	43.8	8,890	28,590	23,620	17,230	12,030
96	4,030	0.25	4,030	4,030	4,030	50.1	8,260	25,520	19,890	13,270	9,210
108	3,580	0.32	3,580	3,580	3,370	56.3	7,550	22,440	16,370	10,480	7,280
120	3,220	0.39	3,220	3,220	2,730	62.6	6,790	19,440	13,270	8,490	**
144	2,690	0.57	2,690	2,690	1,900	75.1	5,510	13,960	9,210	**	**
168	2,300	0.77	2,300	2,090	1,390	87.6	4,520	10,250	6,770	**	**
180	2,150	0.89	2,150	1,820	1,210	93.9	**	8,930	**	**	**
192	2,020	1.01	2,020	1,600	1,070	100.2	**	7,850	**	**	**
216	1,790	1.27	1,690	1,260	840	112.7	**	**	**	**	**
240	1,610	1.57	1,370	1,020	680	125.2	**	**	**	**	**

Bearing Load may limit load

* Load limited by spot weld shear

** Not recommended - KL/r exceeds 200

Notes

- The beam capacities shown above include the weight of the strut beam. The beam weight must be subtracted from these capacities to arrive at the net beam capacity.
- Refer to the latest Haydon Engineering Catalog in our Literature Section for reduction factors for unbraced lengths or call us 1-800-2-HAYDON.

3. Allowable beam loads are based on a uniformly loaded, simply supported beam. For capacities of a beam loaded at midspan at a single point, multiply the beam capacity by 50% and deflection by 80%.

4. The above chart shows beam capacities for strut without holes. For strut with holes, multiply by the following:
 OS by 88%

Project Information			
Project:		Notes:	
Address:			
Contractor:			
Engineer:	Date:		
Approval			
<input type="checkbox"/> Approved <input type="checkbox"/> Approved as Noted <input type="checkbox"/> Not Approved		Signature:	
		Remarks:	